

**Metalliske materialer**  
**Rør**  
**Flensprøving**  
**(ISO 8494:1998)**

Metallic materials  
Tube  
Flanging test  
(ISO 8494:1998)

---

**Nasjonalt forord**

Den engelskspråklige versjonen av europeisk standard EN ISO 8494:2004 er fastsatt som Norsk Standard NS-EN ISO 8494:2004.

**National foreword**

The English language version of European Standard EN ISO 8494:2004 has been adopted as Norwegian Standard NS-EN ISO 8494:2004.

English version

## Metallic materials - Tube - Flanging test (ISO 8494:1998)

Matériaux métalliques - Tubes - Essai de rabatement de  
collerette (ISO 8494:1998)

Metallische Werkstoffe - Rohr - Bördelversuch (ISO  
8494:1998)

This European Standard was approved by CEN on 1 July 2004.

CEN members are bound to comply with the CEN/CENELEC Internal Regulations which stipulate the conditions for giving this European Standard the status of a national standard without any alteration. Up-to-date lists and bibliographical references concerning such national standards may be obtained on application to the Central Secretariat or to any CEN member.

This European Standard exists in three official versions (English, French, German). A version in any other language made by translation under the responsibility of a CEN member into its own language and notified to the Central Secretariat has the same status as the official versions.

CEN members are the national standards bodies of Austria, Belgium, Cyprus, Czech Republic, Denmark, Estonia, Finland, France, Germany, Greece, Hungary, Iceland, Ireland, Italy, Latvia, Lithuania, Luxembourg, Malta, Netherlands, Norway, Poland, Portugal, Slovakia, Slovenia, Spain, Sweden, Switzerland and United Kingdom.



EUROPEAN COMMITTEE FOR STANDARDIZATION  
COMITÉ EUROPÉEN DE NORMALISATION  
EUROPÄISCHES KOMITEE FÜR NORMUNG

**Management Centre: rue de Stassart, 36 B-1050 Brussels**

## **Foreword**

The text of ISO 8494:1998 has been prepared by Technical Committee ISO/TC 164 "Mechanical testing of metals" of the International Organization for Standardization (ISO) and has been taken over as EN ISO 8494:2004 by Technical Committee EC/ISS/TC 29 "Steel tubes and fittings for steel tubes", the secretariat of which is held by UNI.

This European Standard shall be given the status of a national standard, either by publication of an identical text or by endorsement, at the latest by January 2005, and conflicting national standards shall be withdrawn at the latest by January 2005.

This document supersedes EN 10235:1993.

According to the CEN/CENELEC Internal Regulations, the national standards organizations of the following countries are bound to implement this European Standard: Austria, Belgium, Cyprus, Czech Republic, Denmark, Estonia, Finland, France, Germany, Greece, Hungary, Iceland, Ireland, Italy, Latvia, Lithuania, Luxembourg, Malta, Netherlands, Norway, Poland, Portugal, Slovakia, Slovenia, Spain, Sweden, Switzerland and United Kingdom.

## **Endorsement notice**

The text of ISO 8494:1998 has been approved by CEN as EN ISO 8494:2004 without any modifications.

# Metallic materials — Tube — Flanging test

## 1 Scope

This International Standard specifies a method for determining the ability of metallic tubes of circular cross-section to undergo plastic deformation during flange formation.

This International Standard is intended for tubes having an outside diameter no greater than 150 mm and a wall thickness no greater than 10 mm, although the range of diameters or wall thickness for which this International Standard is applicable may be more exactly specified in the relevant product standard.

## 2 Symbols, designations and units

Symbols, designations and units for the flanging test of tubes are given in table 1 and are shown in figure 1.

Table 1

Symbol	Designation	Unit
$a^a$	Wall thickness of the tube	mm
$D$	Original outside diameter of the tube	mm
$D_u$	Maximum outside diameter of the flange	mm
$L$	Length of the test piece before the test	mm
$R$	Corner radius of the flanging tool	mm
$\beta$	Angle of the conical mandrel	degree

<sup>a</sup> The symbol  $T$  is also used in steel tube standards.

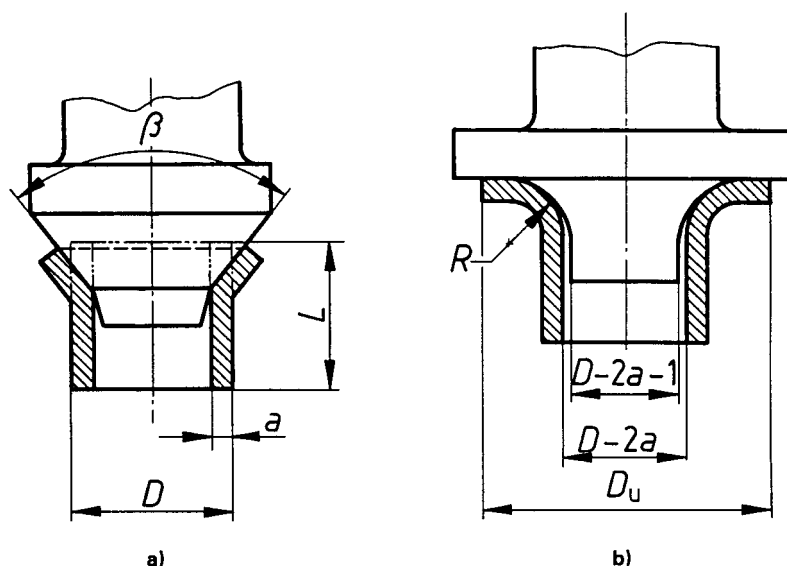

Figure 1